

**DISTRIBUTION STATEMENT A**  
Approved for Public Release  
Distribution Unlimited

ISABE 99-7285

**ROLLS-ROYCE INDUSTRIAL TRENT: COMBUSTION AND OTHER TECHNOLOGIES**

**C.Barkey, S.Richards, N.Harrop, P.Kotsioprifitis, R.Mastroberardino, D.Squires, T.Scarinci**  
Rolls-Royce Canada  
9545 Cote-de-Liesse  
Dorval, Quebec  
Canada H9P 1A5

Abstract

In 1993, Rolls-Royce Gas Turbine Engines Canada Inc. (today an integral part of Rolls-Royce Canada) was launched to develop a dry-low-emissions (DLE) industrial derivative of the aero Trent engine. The aero Trent is now in service powering the Boeing 777 aircraft and the Airbus A330. The Trent 800 is certified at 90,000lb thrust and was the first engine in the world to be certified at that level. The industrial version builds on this pedigree and follows a long lineage of aero derivative industrial engines. It has the declared objectives to provide customers with 50MW of power, a life of 25,000 hours for all hot end parts and 50,000 hours on other components, and a thermal efficiency of 42 per cent. To build on the experience of the Rolls-Royce RB211-DLE industrial engine, the selected combustor configuration for the 35:1 compression ratio engine was of a cannular design with 3 lean-premix stages in series (primary, secondary, and tertiary stages). The development program for natural gas

operation is now at a stage where the main advantages of the 3-stage combustor and other technology features on the Trent can be documented.

1. Introduction

The Rolls-Royce industrial Trent is derived from the highly successful aero Trent which entered service in 1995 and is now in service with 13 operators across the World. The aero Trent has accumulated over 1,000,000 hours of operation. The capability of the aero Trent engine ranges from the Trent 768 certified at 68,000 lbf thrust to the soon-to-be certified Trent 895 at 95,000 lbf thrust. Additionally the Trent 8115 is under study which will deliver 115,000 lbf.

The industrial Trent is derived from the Trent 892, which was certified at 92,000 lbf thrust in 1995. This mark of aero Trent is now in service with seven operators across the world and has already accumulated over 500,000 hours of operation.

**ROLLS-ROYCE INDUSTRIAL TRENT GAS TURBINE ENGINE**

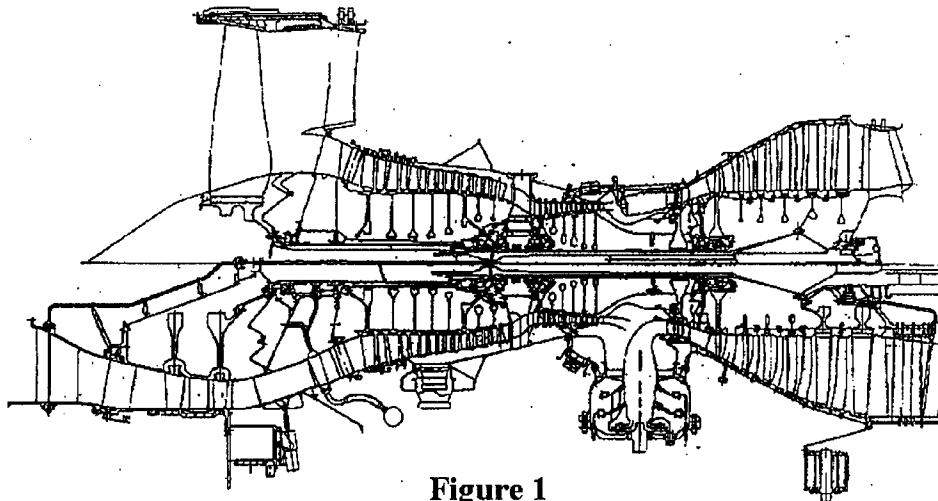

Figure 1

20000208 058

Currently the industrial Trent is available in two variants; industrial Trent 5050 which is designed to run with an LP shaft speed of 3000 RPM(50Hz) and industrial Trent 5060 which is designed to run with an LP shaft speed of 3600 RPM (60Hz). The core and LP turbine are common to both variants. Many parts are identical with the aero parent whilst some parts are geometrically and functionally the same but the material has been optimised for an industrial application. As can be seen in figure 1, the two areas that are significantly different are the LP compressor and the Dry Low Emissions (DLE) combustor technology. DLE technology brings with it the challenges of accurate fuel metering. Less obvious from the figure is the fact that the industrial Trent incorporates active thrust piston load control.

The advantages of an aero-derivative are numerous and considerable to both the supplier and the customer. The supplier benefits from the use of aero common components which greatly reduces the cost to develop an industrial product. The reduction in direct development costs can be as high as 75% and this is augmented by latent reductions resulting from the use of common methods and processes. This leaves the industrial engineering team to focus on the industrial unique components.

The customer benefits from the lower cost of the product due to the use of common parts and through the considerable confidence that may be taken from the knowledge that the foundation of the product is a high integrity, aerospace standard product. This paper will focus on the challenges presented to the engineering team in taking an aero product and modifying it for industrial use. The industrial Trent provides a case study.

The business opportunities for the industrial Trent are many. The industrial Trent is currently in operation in simple and combined cycle operation for the generation of electricity (and steam in combined cycle). Two obvious additional business opportunities are marine applications (both commercial and military) and oil and gas pumping. This paper focuses on the Trent in its current application – power generation.

Aero-derivative gas turbines offer several key advantages over alternative forms of power generation. Amongst these are low capital cost, short construction and maintenance times, low environmental impact, high thermal efficiency and fast, flexible operation. The time between launching a project and entering commercial operation can be as low as 9 months which is largely due to a low requirement for ancillary equipment. Maintenance activities can also be conducted in short timescales through a modular approach. Aero-derivative gas turbines can go from a state of complete shut-down to base load operation in a matter of minutes and have a high cyclic life capability. This flexibility makes aero gas turbines ideally suited to grid support (mid-merit operation).

## 2. The LP Compression System

The LP Compressor is a two-stage replacement for the aero Fan. It is driven by the LP turbine and has a maximum pressure ratio of 1.8 to 1. The LPC absorbs circa 20% of the total LPT power. The residual LPT power is directed to the electrical generator which is directly driven by the LP turbine. This approach differs from that adopted on other industrial engines (eg Rolls-Royce industrial RB211, Spey) where a free power turbine is used (see figure 2). This approach permitted more commonality with the aero product (the first three stages are exactly as aero).

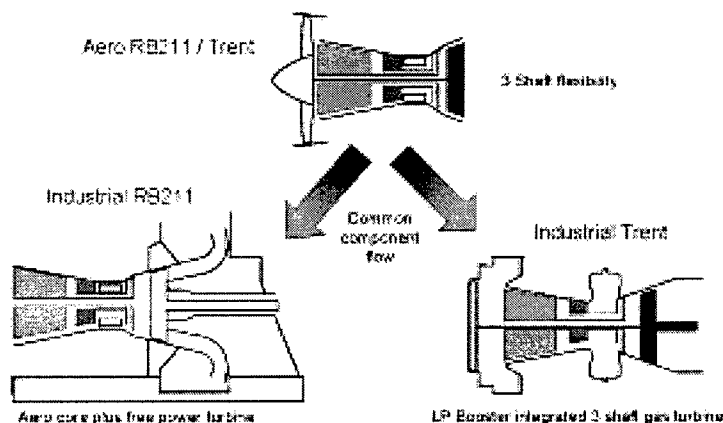

Figure 2

## Start sequence

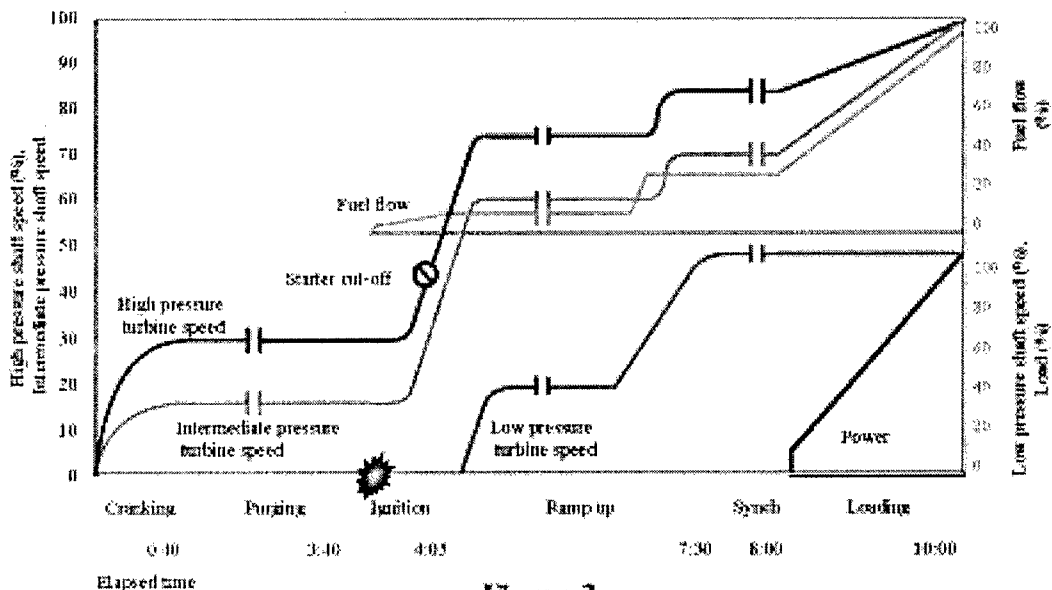
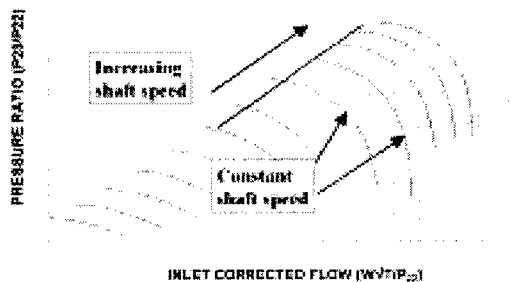

Figure 3

Figure 3 illustrates the sequence of events during a start to synchronous idle (synchroniser enabling point) and then as the unit is synchronized to the grid and loaded to power. As can be seen, the unit is started and brought to synchronous idle where the generator and therefore LP shaft speed matches the grid frequency. The conditions for the gas generator core are similar to flight idle for an aero-engine but the LP shaft speed is far higher than for flight idle (and is already at the design point speed). The unit is then connected to the grid and brought up to base load. During the loading process the IP and HP shaft speeds increase but the LP shaft speed remains constant. The design point for the unit is base load. At off-design conditions the LP shaft runs at constant (line synchronous) speed.

As the following figure illustrates, a compressor running at constant speed will operate over a relatively small range of flow<sup>\*</sup>. Conversely, a compressor operating over a wide range of speeds will operate with a considerable range of inlet flow. The incompatibility between the constant speed LP compressor and the non-

constant speed IP and HP compressors becomes obvious. If the compressors are well matched at base-load (i.e. the design point) then the LP will be driven towards surge as the IP and HP shafts decelerate during the unloading of the unit.



The chosen solution is to extract flow from between the LP and the IP compressors. This allows the LP compressor to operate at a high flow rate while the IP and HP operate over a wide range of flows.

\* More correctly one should consider non-dimensionalised speed and flow. In the case of the LPC the inlet conditions may be considered to be constant and hence there is no difference.

To extract this flow, doors were designed at the rear of the LP compressor which allow the flow to discharge overboard. A total of eighteen doors are fitted. They are all modulated simultaneously and their position is closed-loop controlled to provide the appropriate flow into the IP compressor. The flow extraction increases the LP flow thus maintaining adequate surge margin. Eighteen modulating doors were selected in preference to discrete (non-modulating) doors as the flow must be extracted equally from all around the circumference. The use of a discrete system (with additional doors opening fully or closing fully to control flow) would cause a significant disturbance to the rear of the LPC resulting in an unacceptable loss of LP surge margin.

The doors extract up to 50% of LP inlet flow at low engine power. As the power from the engine increases the doors are scheduled to close and are fully closed by mid power.

### 3. Combustion

The industrial Trent must comply with the emissions legislation applicable to land-based, power producing machines. To meet these requirements the combustion process must be precisely controlled.

High level of NOx result from a high local flame temperature. Conversely high levels of CO result from too low a flame temperature.

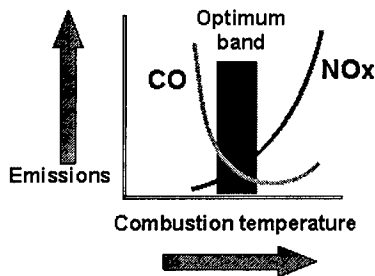

It is generally agreed that the optimum temperature to minimise NOx and CO is 1850K. Combustion noise is another parameter which has to be accounted within the optimisation of the fuel scheduling. This has been experienced by most lean-premixed combustor designs and is now well reported. Scarinci and Halpin' describe this problem in detail for the industrial Trent.

It is not the aim of this paper to present a detailed description of these challenges but rather to describe the approach adopted for the Trent.

All DLE designs require precise control of the combustion flame temperatures. At any given operating condition the total quantity of fuel flow required by the engine is dictated by the electrical power output and the thermal efficiency of the engine. This then leaves the combustion engineer with the task of how to configure the combustion system so that the total fuel flow may be accommodated in the combustor and combusted in such a way that locally the required flame temperature is achieved.

Essentially two options have evolved. The first and most common is fuel staging, which can be done either in parallel or in series. In staged combustion the combustor is configured into a number of zones, each taking a certain fraction of the engine air flow. Fuel is mixed with the air and combusted in the zone. The industrial Trent has three zones in series as can be seen in the following figure.

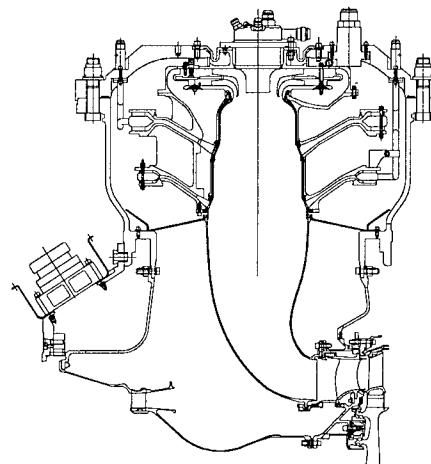

The discharge from the primary zone mixes with the flow entering through the secondary zone and assists the combustion process. Similarly the discharge from the secondary zone mixes with the tertiary zone. The fuel flow to each zone is accurately metered to ensure the required zone temperature is achieved. At extremely low conditions (before synchronisation to the grid) only the primary flows and it is not possible to guarantee low levels of NOx. Above synchronisation and at low power levels the primary and secondary zones work together to control emissions. Above 50% power all three zones are active. Under such circumstances the primary and secondary are controlled to a zone temperature while the tertiary take the surplus fuel. This makes for an extremely flexible system.

The second option with staged schemes is parallel combustion. A parallel design will typically have an

annular combustor configuration similar to most modern aero engines. The combustor has an extremely high number of fuel injectors dispersed uniformly around the combustor. The design relies upon the principle that each injector feeds a stream of air and that there is little mixing between the streams. In such a manner each injector may be considered to be a combustor on its own. Hence the total fuel flow is distributed across as many injector as necessary to achieve the target zone temperature. As power is increased additional injectors are brought on-line so as to maintain the required zone temperature.

The final option is to control the flow of air into the combustor. This requires the use of variables within the combustion system to direct more or less air into the combustion zone as necessary. The remaining air is returned downstream of the combustor.

The use of three stages of combustion on the industrial Trent was driven by the high pressure ratio (over 35:1) and the high turn-down ratio on the fuel flow. The use of a series combustor follows the success of the RB211 DLE. The RB211 requires only two stages due the lower turn down ratio. The three stage configuration is now proving to be extremely versatile and providing many benefits in defining fuel schedules which navigate around the regions of combustion instability. At the time the industrial Trent combustor was being designed little was known about DLE combustor noise (more correctly called thermoacoustic resonance). With the emergence of this problem the approach taken on the industrial Trent has been similar to that taken elsewhere. The three stages of combustion provides 2 independent degrees of freedom in defining the fuel schedule whilst maintaining power. Fuel schedules have been developed to control the amplitude and frequencies of the combustion instability as reported by Scarinci and Halpin<sup>1</sup>.

An additional benefit of a series combustor over a parallel combustor is the ability to *burn-out* all of the CO in the final stage. This means that the fuel schedules for the initial stages can be optimized with regard to noise and NO<sub>x</sub> but may not necessary meet the CO requirements. The CO is then eliminated in the final stage.

#### 4. Combustion Zone Temperature Control

From the above discussion it can be seen that an ability to precisely control zone temperatures is key to delivering optimum combustor performance on DLE engines. The target zone temperature is provided through a look-up table which resides in the engine management system (EMS). To deliver the required

zone temperature the EMS measures the combustor inlet conditions (temperature and pressure) and calculates the necessary temperature rise in each zone. The following figure illustrates all the variables that impact on the temperature rise (and hence zone temperature).

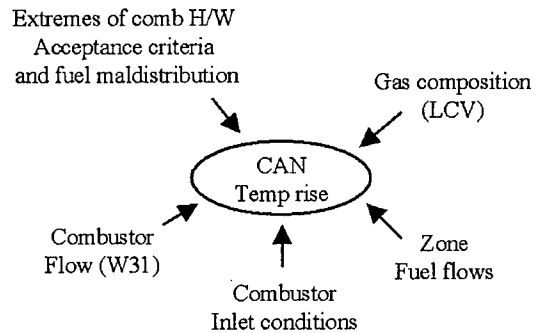

Arguably the most difficult to determine is the combustor air flow (W31). There are several ways to arrive at W31, the two most promising methods are as follows. The most accurate method derives flow from choked flow conditions through the high pressure turbine nozzle. This is the most accurate scheme and the one used on both the industrial Trent and the industrial RB211 (DLE). It is also the most complex and requires an iterative approach. The alternative is based on the high pressure compressor flow function. This is far simpler to implement but offers less accuracy especially during transients and degrades with engine deterioration.

The industrial Trent method is as follows. The combustor inlet conditions (temperature and pressure) are determined based on measurements at the HPC exit. The fuel flow is independently metered to each of the combustor zone manifolds (one manifold for the primary, one for the secondary, etc). The total fuel flow is calculated by summing the individual flows. The industrial Trent HPT nozzle is choked at all conditions above synchronization. All the fuel properties are entered in the EMS along with other information including the capacity of the HPT nozzle. An iterative scheme is then used to calculate the combustor air flow by satisfying the choked condition across the nozzle. Once the total air flow is known all that remains to be done is to calculate the zonal air flow and schedule fuel to that zone to delivery the target zone temperature. What makes this task difficult is the requirement to achieve very accurate zone temperature control.

To meet the exacting requirements the following steps are necessary. Engine and site specific data is entered

into the EMS. The HPT nozzle capacity is entered based on build measurements. Information on the combustors is entered to define the air flow splits. For the current site locations (UK and Canada) the gas composition is relatively stable and therefore it is acceptable to enter nominal site gas composition. For some locations the variation in gas composition may preclude this and an alternative approach may be required. For such locations two options exist. One is to fit on-line gas analysis linked to the EMS. The other approach is to introduce a method of adaptive fuel control that trims the fuel schedules to control NOx and noise. Both options have been evaluated.

Fuel flow measurement and metering is also a challenge and has the potential to dominate the zone temperature inaccuracy. The chosen solution is a highly repeatability shoe valve (a cylinder that rotates within a close fitting cylindrical outer to uncover an aperture) with a external angular resolver. High precision temperature and pressure measurements are required to derive the flow and corrections are made for the gas properties.

As a result of all the above steps the combustor zone temperature can be accurately controlled for all three zones. Consequently emissions can be satisfied across a large envelope and combustor noise avoided with confidence.

### 5. Performance

At ISO conditions the industrial Trent delivers 51MW\*. On cold day operation the power is flat rated at just below 60MW. On hotter days the engine is limited to a constant HP turbine Stator Outlet Temperature (SOT). This capability makes the industrial Trent the most powerful aero-derivative gas turbine yet developed. This is a direct consequence of the high pressure ratio cycle and the high firing temperature capability of the aero engine. The engine was sized to have similar air flow and core engine performance as the aero engine. Studies indicated that 50MW gives a very competitive cost for electricity for IPP (independent power producer) operation when used in simple or combined cycles.

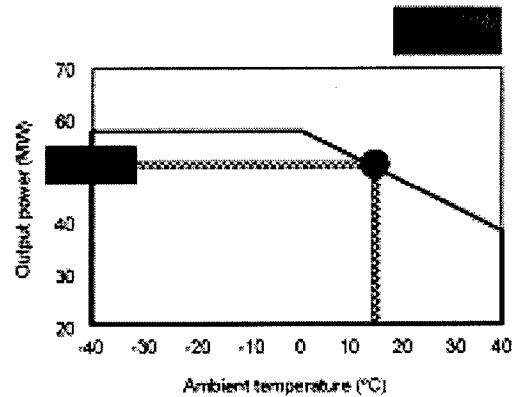

The industrial Trent simple cycle thermal efficiency is 42% at ISO conditions rising to nearly 45% on cold days. This high efficiency is again a consequence of the high pressure ratio, highly efficient components from the aero engine.

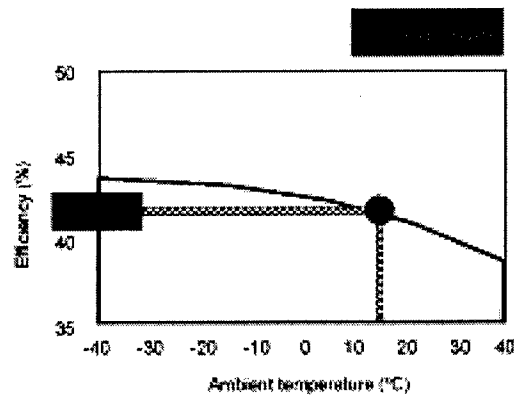

In combined cycle applications steam is produced for process use or may be used in a steam turbine to augment the electricity produced. Figure 4 illustrates a typical combined cycle.

\*Uninstalled shaft power (i.e. negligible inlet and exhaust losses).

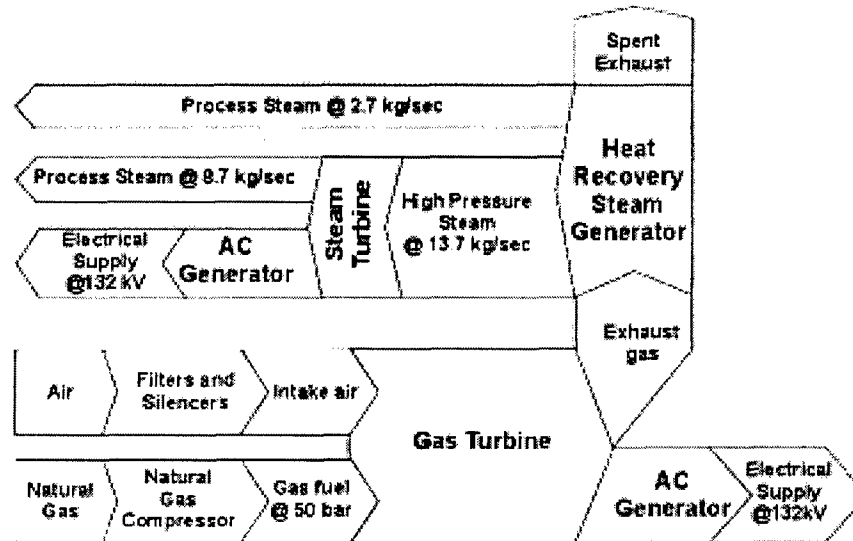

**Figure 4**

6. Active bearing load control

Axial loads are exerted on the shafts by the turbines and compressors. The loads consist of two elements. The major element is a simple force due to a pressure differential acting on an area. In the case of the compressor this results in a forward force trying to push the compressor out of the engine. For a turbine the direction is opposite. This force acts not only on the blading but also within the cavities formed by the secondary air system. The second element is usually minor in comparison and is mentioned here for completeness. This element is due to the momentum change of the fluid as it passes through the blading and augments the load due to the pressure force.

On the aero Trent this results in two very large but opposing forces applied at each end of the shaft. The net effect is a small residual axial load.

In the case of the industrial Trent, the LPC is much smaller than the aero fan and the LPC load does not offset the substantial LPT load. The net load is a considerable rearward load.

The secondary air flow cavities were mentioned above. The pressure within these cavities is a function of the source of the air, the sink for the air and the sealing

arrangement. Indeed one can configure the cavity to play a beneficial role in offsetting the axial shaft load. Balance pistons have often been used on gas turbines but usually in a passive manner. On the industrial Trent the pressure in two cavities is actively controlled.

Air is taken from the rear of the IP compressor. It is then fed to the cavities via two, independent valves. The valve positions are under the control of the EMS which modulates their position to achieve a desired pressure. The pressure is calculated within the ECS and is the pressure required to maintain an acceptable residual load on the bearings which is neither too large (reduced bearing fatigue life) or too small (resulting in rapid failure due to skidding).

The loads from the turbines and compressors are not directly measured but are derived from a series of look-up tables in the EMS. The tables are non-dimensionalised using salient engine parameters including compressor inlet and exit pressures. It is only by having an active control system of this complexity that acceptable bearing loads can be achieved across the entire engine operating envelope, and hence the required 50,000 hours B<sub>10</sub> life is achieved.

## Evolution of the RB211 and Trent families

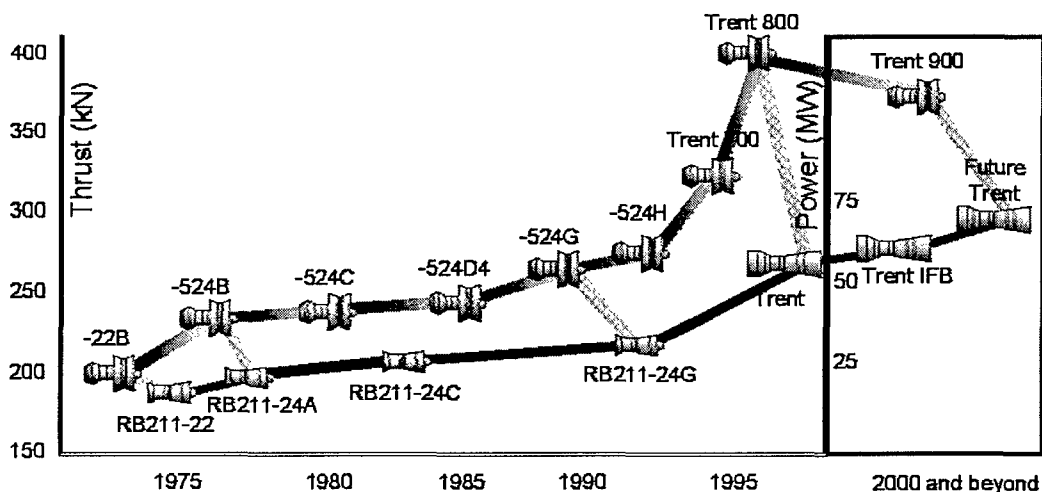

Figure 5

### 7. The future

The industrial Trent has considerable potential to grow and be used in other applications. The opportunities to expand into other market sectors was mentioned in the introduction where marine applications and oil and gas pumping were identified. The industrial Trent can also grow in its current market sector (i.e. power generation). Figure 5 illustrates the opportunities to grow through the introduction of aero developments or the introduction of industrial specific technologies.

The current industrial Trent is nominally rated at 50MW. (This is the ISA rating, the cold day rating is 60MW). As the aero core is developed and the components are cleared to higher temperature ratings it will be possible to increase the power capability of the industrial Trent by adoption of the latest aero components. In parallel with this, industrial specific technologies will be pursued which offer a combination of power and efficiency gains. One such technology is inlet fog boost where a very fine mist of water is sprayed in front of the LPC. The effect on the engine is similar to inlet chilling but is far more efficient and the ancillary hardware required is much less complex and costly.

Through a combination of these options it will be possible to upgrade the industrial Trent from its current rating of 50MW (ISO) to approaching 75MW – a 50% increase.

### 7. Conclusions

The industrial Trent is a true aero derivative having many common components with the Rolls-Royce Trent

892. This brings many benefits to both the supplier and the customer. One of the prime benefits to the supplier is greatly reduced development costs. Despite this the remaining technical challenges are considerable and as complex as any undertaken to develop the aero product. The industrial Trent incorporates many novel features. The following are key amongst these: The dry-low-emissions combustion system and associated fuel control which satisfies the strict legislative requirements. The redesigned LP compression system and LP bleed flow arrangement which enabled the use of the aero LPT whilst operating at constant LP speed. The active bearing load control without which acceptable bearing lives could not have been achieved.

In its first full year of International operation the industrial Trent has already accumulated over 10,000 hours with its four operators across the World. The demonstrated performance is consistent with our high expectations.

### 8. References

Scarinci, T & Halpin, J, 1999, "Industrial Trent Combustor – Combustion Noise Characteristics", paper 99-GT-9, ASME Gas Turbine & Aeroengine Congress & Exhibition June 7 – June 10, 1999

### 9. Acknowledgements

Thanks to Brian Coleman and Martin Stanton who reminded me of all the advantages gas turbines (and specifically aero derivatives) bring to customers.

Thanks to Graham Reynolds, Steve Bashforth and Dave Jarvis who reviewed the paper.